

ZeeKey

IEEE802.15.4 Sensor Plattform v1.3

The ZeeKey is a versatile sensor platform integrating RF module, power supply and various sensors. This version of the ZeeKey features a sensor to measure light, temperature and orientation of the device, which sports dimensions of the 40x19x7.1 mm (excluding battery pack).

Hardware Components

Power

The Keychain features a MAX1947 ETA33 step-up converter, which converts a DC power source from +0.8 to +3.0V to the main power supply of +3.3V. Suitable sources are a single 1.5V battery cell, a 3V Lithium button cell or two 1.5V battery cells, as well as 1.2V and two 1.2V accumulators.

Core

The system is built around a MeshNetics ZDM1281-A2 module, which is capable of IEEE 802.15.4 and ZigBee communication. The module contains an ATmega1281 micro controller as well as an AT86RF230 radio chip. Both components are shielded and encapsulated on a small circuit board, requiring only a single power supply voltage.

Sensors

This version of the ZeeKey features three sensors, which can be used to gather information from the Keychain's environment.

The ADXL330 **accelerometer** can be used to distinguish the three-dimensional orientation of the Keychain. The sensor readings can be

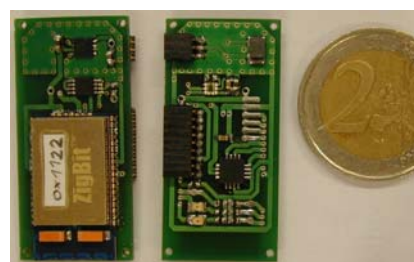

ZeeKey pcb – top and bottom views

acquired by reading the values of the ADC port 1-3 of the Atmega1281 micro controller.

An Intersil ISL29003-IROZ **light sensor** can detect up to 64.000 Lux (a well lighted office has approx. 500 Lux). The resolution of the sensor can be modified, depending on the expected maximum light value.

For **temperature** measurements, an LM75 temperature sensor is available, offering 0.5° C resolution..

I/O options

Two LEDs are available for local feedback simple status reports. For more detailed information and debugging, the UART of the microcontroller can be used.

There are four free GPIO pins which are connected to a 100k pull-up resistor, enabling push-button interaction without additional components. Two of these GPIO pins can be used for hardware interrupts, to wake the micro controller from sleep modes.

Software Components

We support a range of radio stacks and software environments to cover different system requirement sets. Besides the commercial Meshnetics ZigBee, we support two open alternatives:

MeshNetics openmac

Openmac is a simple radio stack, implementing parts of the IEEE 802.15.4 MAC

and PHY layer for star networks. Especially for simple data collecting purposes, this stack can be used. In our current development cycle, multiple Keychains are separated into data transmitters and receivers. A transmitter collects information of its sensors, and sends them by broadcast, whereas a receiver ignores its own sensor data and sends the received data packets via UART to a host computer. On the host computer, a small C-file parses the information from the UART, and creates data structs for each packet for further use in other programs.

SICS Contiki with uIPv6 / SICSLoWPAN

Contiki is a versatile operating system designed for small microcontrollers by the Swedish Institute of Computer Science (SICS). It offers a stack that implements an IPv6 transport over Low power Wireless Personal Area Networks (6LoWPAN). This enables the ZeeKey to communicate with each other and the Internet over IPv6 links. Stack features include UDP, TCP, uni- and multicast transports, IP header compression techniques, neighbour and router discovery. A simple web server implementation enables high-level access to sensor data.

Board support for ConTiki on the ZeeKey platform is being finalized and will be complemented by an Internet access routing device in Q2 2009.

Advanced Sensor Library Components

We have implemented a set of higher level sensor analysis components that exploit the sensors and local, power-optimized data processing in diverse application fields like multimedia remote controls, geo-spatial information services and human activity tracking.

Design options

The ZeeKey platform can easily be customized to application specific needs, please contact us with your requirements.

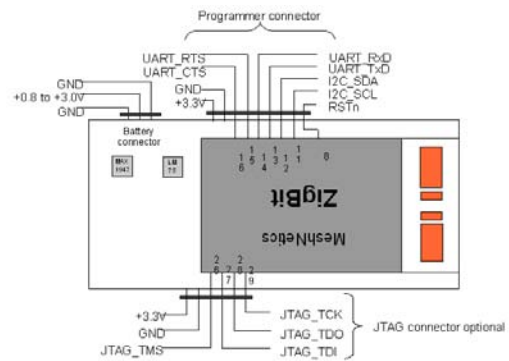

ZeeKey programmer interfaces

Contact

Dr. Simon Vogl

Research Studios Austria Forschungsges.mbH
Studio Pervasive Computing Applications
Aubrunnerweg 1
4040 Linz
Austria

simon.vogl@researchstudio.at

<http://www.researchstudio.at>

<http://pervasive.researchstudio.at>

Office: +43 732 2468 5350

Mobile: +43 664 82 51 274